

# Q31LP ASSEMBLY INSTRUCTIONS

**Figure 1**

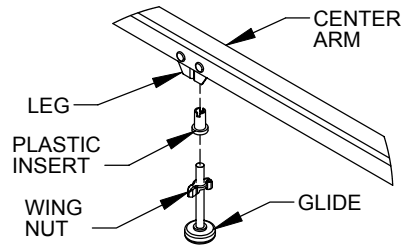

**Figure 2**

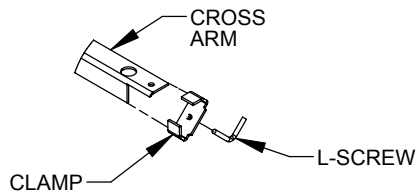

**Figure 3**

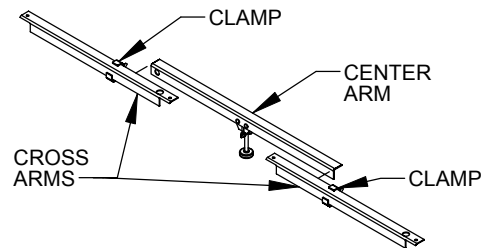

**Figure 4**

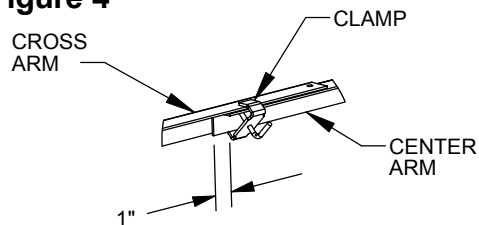

**Step 1:** Tap PLASTIC INSERT into LEG. With flat side up, screw WING NUT onto GLIDE. Thread GLIDE into PLASTIC INSERT. See Figure 1.

**Step 2:** Loosely attach L-SCREWS to CLAMPS and slide CLAMPS onto CROSS ARMS as shown in Figure 2.

**Step 3:** Place CENTER ARM under CROSS ARMS and slide CLAMPS onto overlapped CROSS/CENTER ARMS as shown in Figure 3.

**Step 4:** Adjust to width needed and position each CLAMP one inch from the edge of the lower CROSS ARM as shown in Figure 4. Tighten L-SCREWS.

*If using one cross support:*  
Place assembled cross support in the center of the bed as shown in Figure 5.

*If using two cross supports:*  
Place assembled cross supports between side rails, approximately 40 to 50 inches apart as shown in Figure 6.

**Step 5:** Attach CROSS ARMS to SIDE RAILS. For metal side rails use NUTS and BOLTS as shown in Figure 7. For wood side rails use WOOD SCREWS as shown in Figure 8.

**Step 6:** Adjust GLIDES so that they touch the floor. Tighten WING NUT against PLASTIC INSERT.

**Note:** *There must be at least one inch of the glide stem in the plastic insert.*

**Step 7:** Tighten all nuts, bolts, and L-screws.

**Figure 5**

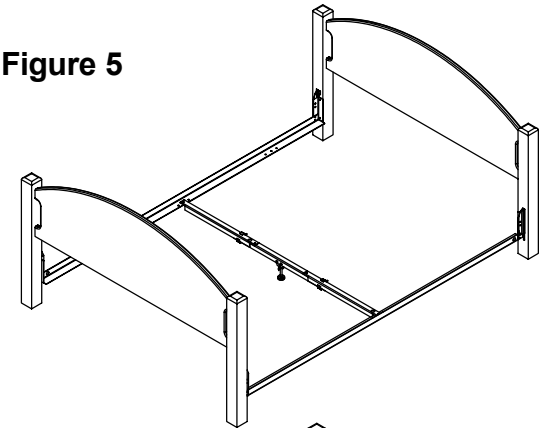

**Figure 6**

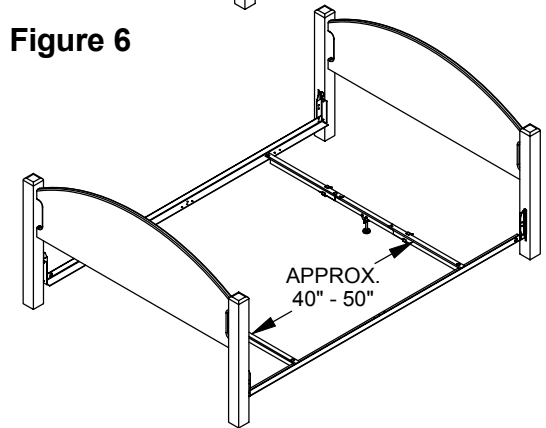

**Figure 7**

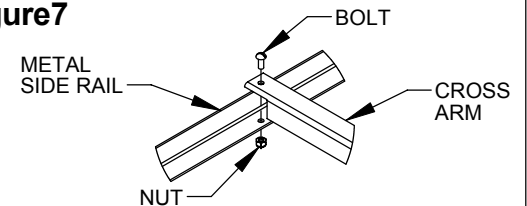

**Figure 8**

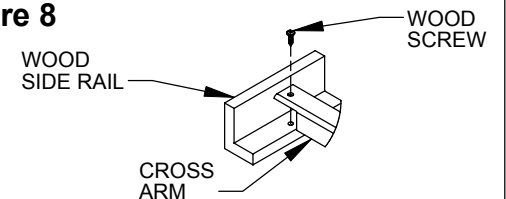

*Leggett & Platt*  
INCORPORATED

DATE  
8-22-07

DWG. NO.  
**99300978**

DO NOT SCALE DRAWING SHEET 1 OF 1