

ULTRA QPU/KPU ASSEMBLY INSTRUCTIONS

Note: If the height from the floor to the bottom of boxspring exceeds 11", the PLX-18 Power-Lift Extension Kit will be needed. These extension kits can be purchased from your local retailer. (The PLX-18 Extension Kit cannot be used with the QPU-5 or the KPU-5.)

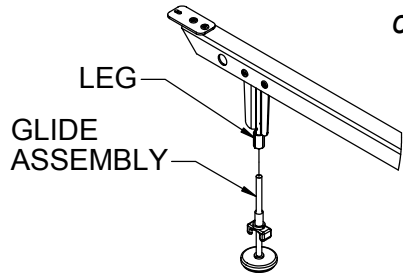

FIGURE 1

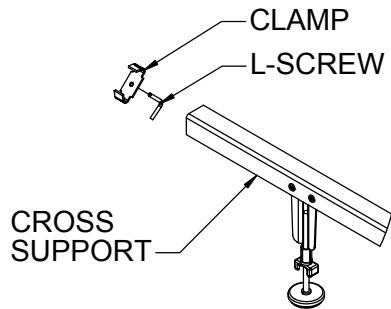

FIGURE 2

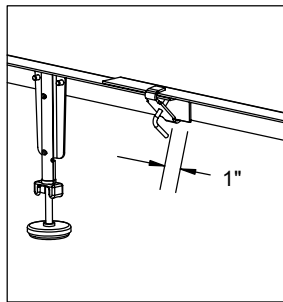

FIGURE 3

Step 1 Tap GLIDE ASSEMBLY into LEGS of cross supports until plastic insert is fully seated or install PLX-18 Extension Kits if required. See Figure 1.

Step 2 Loosely attach L-SCREW to CLAMP and slide onto CROSS SUPPORT as indicated in Figure 2. Overlap cross supports (*for KPU, long cross support should be underneath*) and slide clamp onto both cross supports. Adjust cross support to width needed. Position CLAMP 1" from the end of the LOWER CROSS SUPPORT as shown in Figure 3 and tighten L-screw.

Step 3 Place the clamped cross supports between side rails, approximately 20 to 28 inches apart as shown in Figure 4.

Step 4 Secure cross supports to side rails as detailed in Figure 5.

Step 5 *Adjust glides to rest on the floor surface.* Lock glides in place by turning wing nuts tight against the plastic inserts.

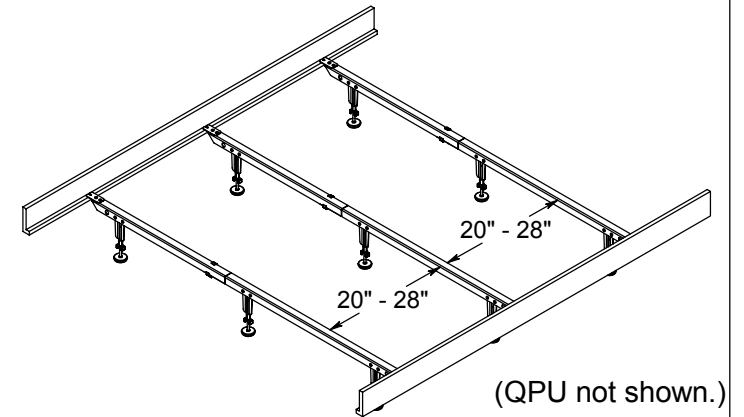
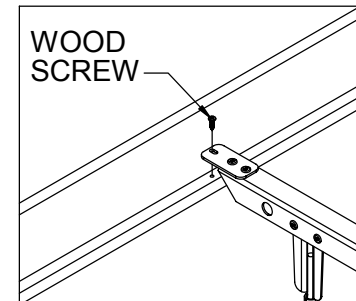
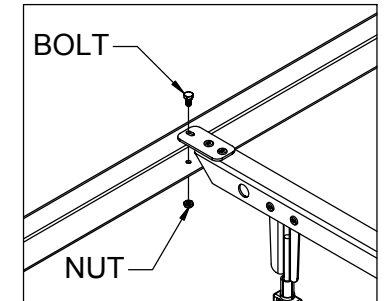

FIGURE 4



WOOD SIDE RAILS



METAL SIDE RAILS

FIGURE 5