

PLX-18 POWER-LIFT EXTENSION KIT ASSEMBLY INSTRUCTIONS

Determine the height from the floor to the bottom of the boxspring.

For heights of 11" - 14":

Bolt leg extender to the leg, using the hole positioned at the **top** of the leg. See View 1.

For heights of 14" - 18":

Bolt leg extender to the leg, using the hole positioned at the **bottom** of the leg. See View 2.

- Tap glide assembly into leg extender until plastic insert is fully seated.
- After bed frame/rail and cross supports have been fully assembled and secured, adjust glide height to clear floor or carpet surface by 1/4 inch. Lock glides in place by turning wing nuts tight against the plastic inserts.

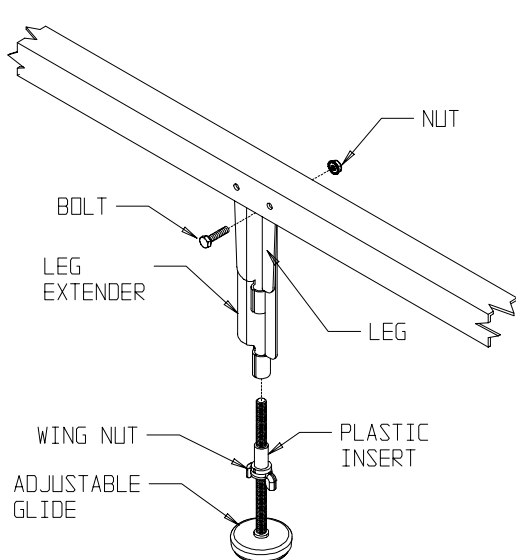

View 1

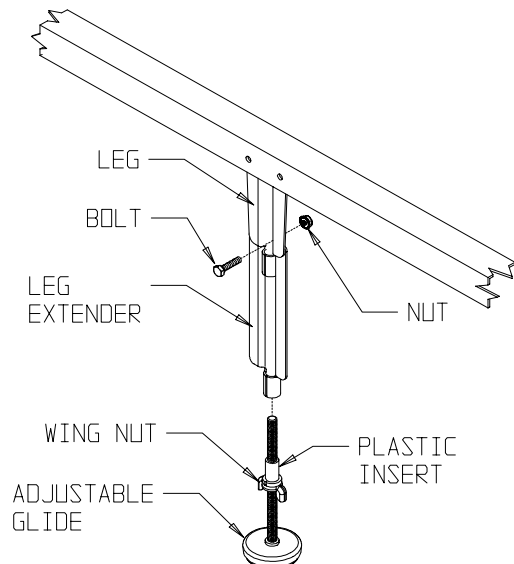

View 2